

A E G I S

Standard-build Gas Assisted Molding Accessories, January 2016 Catalog

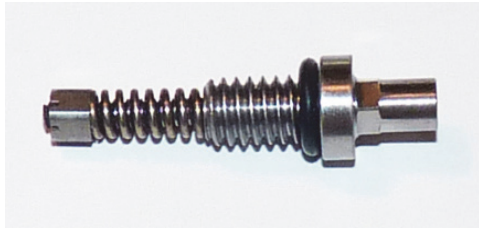

Part No. A3SC312TS – O1 tool steel
Part No. A3SC312SS – 316 stainless steel

Gas Injector – End Discharge.
Self Cleaning, High Flow.

AEGIS' self-cleaning, high flow **A3SC** Series gas injector is unequalled for full pressure profiling capabilities at reduced gas injection pressures. Designed to be a direct remove and replace for any style injectors with 1/4-20 threads, 3/8" Ø shoulder x .180" deep tool bore.



Part No. A4SC312TS – O1 tool steel
Part No. A4SC312SS – 316 stainless steel

Gas Injector – End Discharge.
Self Cleaning, High Flow.

AEGIS' self-cleaning, high flow **A4SC** Series gas injector has the same features as the **A3SC** Series, with a .281" shoulder to fit tighter placement in molds, with 1/4-28 threads.



Part No. A5SC312TS-D

Gas Injector – End Discharge.
Self Cleaning, High Flow Durajector™.

AEGIS' self cleaning, high flow **A5SC** Series gas injector has the same base materials and dimensions as the **A3SC** Series, with a unique titanium nitride coating for exceptional durability when molding reinforced resins. 1/4-20 threads



Part No. A6SC312TS-D

Gas Injector – End Discharge.
Self Cleaning, High Flow Durajector™

AEGIS' self-cleaning, high flow **A6SC** Series gas injector has the same features as the **A5SC** Series, with a .281" shoulder to fit tighter placement in molds. 1/4 - 28 threads

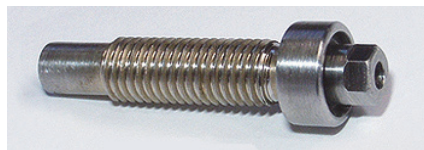

Part No. DET-21

NitroJection Standard Gas Injectors

NitroJection's **DET-21** in-mold gas pins are time tested to provide durable and efficient gas flow for injecting nitrogen and venting pressure from the mold. Overall length 1.375", threads 1/4-28. In stock and competitively priced. 4140 alloy construction. Available with custom dimensions to fit your gas assist molding program.

Replacement, Aftermarket Gas Injectors



Part No. DET-0001ACE

3/16" Replacement Gas Injectors

AEGIS' **DET-0001ACE**, 3/16" overall diameter, is a direct replacement gas injectors in existing molds. Low cost, durable and efficient, but *not* recommended for new applications. 8-32 threads.



Part No. DET-0016ACE

1/4" Replacement Gas Injectors

AEGIS' **DET-0016ACE**, 1/4" overall diameter, is a direct replacement gas injectors in existing molds. Low cost, durable and efficient, but *not* recommended for new applications. 1/4-28 threads.



Part No. DET-AGA1

NitroJection Replacement Gas Injectors – Older Molds

NitroJection's **DET-AGA1** is designed to replace gas pins that were used long before current designs with self-cleaning features, high flow capability and assembly in the open mold were developed. We do *not* recommend this design for new applications.



Part No. ACV-02

JDL Gas Assist Ball Check Valve

Connects 1/8" SS gas line to a gas assist injection nozzle. The "ball check" function prevents resin and gas from reentering the gas line following gas injection. Used in through-the-nozzle gas molding *only*.



Part No. SAN-1

JDL Self Aligning Nozzle Tip

The **SAN-1** assembles into the end of any injection nozzle. When wear occurs, only the spherical tip detail is replaced. It saves you money while ensuring sprue bushing - nozzle tip alignment.

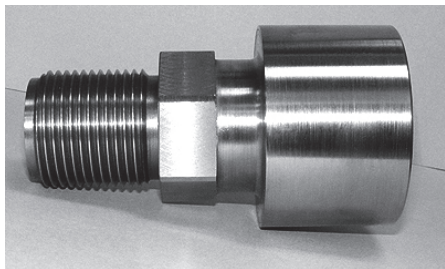

Part No. SRS-2000

AEGIS' SRS-2000 Resin Shutoff

The time-tested automatic (non-hydraulic) resin shutoff valve has been production proven for over 10 years for reliability and cost effectiveness. NO HYDRAULICS, NO SPRINGS, NO SIGNALS REQUIRED!

Standard threads: 1 3/4" – 8; special or metric threads available. Male end "Van Dorn style" taper available at no additional cost.

The *ultimate* resin shutoff valve!

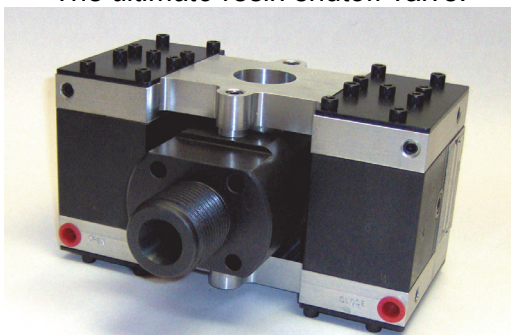

Part No. RSOV-III & Part No. RSOV-IV

JDL Rotary Resin Shutoff Valves, Model III and IV

This patented, hydraulically actuated resin shutoff valve is designed for fast, positive closure of the resin flow path between the machine barrel & resin injection nozzle. Standard threads 1-3/4"-8 both M & F; special threads to meet your requirements.

RSOV-III - for Gas Assist Molding

RSOV-IV for High Pressure Conventional Injection Molding *and* gas injection



Part No. NAS-000 - Nozzle Adapter Shutoff
Part No. NAS-001 - Nozzle Adapter Shutoff w/gas port

NitroJection Self Actuating Nozzle/Resin Shutoff Adapter

Add-On, Self Actuating Nozzle/Resin Shutoff

Converts your standard injection nozzle into shutoff nozzles

- H13 tool steel (hardened)
- Nozzle Thread: Male 7/8"-14
- Through bore: .400" diameter



Part No. DRL-02

JDL Resin Drool Eliminator

The Drool Eliminator uses a very heavy spring-loaded mechanism to prevent nozzle drool. In process, the nozzle moves forward to the sprue bushing, opening the valve for resin injection. After resin injection and packing, sprue break allows the nozzle to close. Unique in the molding industry!

 <p>Part No. CSN-001</p>	<p>NitroJection Self Actuating Gas Assist Nozzle - Resin Shutoff</p> <p>Gas Assist Shut Off Nozzle With Gas Port, 1-3/4"-8 Male THD Rear End, 7/8"-14 Female Front End for Standard Nozzle Tips, 1/8" NPT Gas Port</p> <p>Provides the functions of gas injection nozzle, and, resin shutoff valve!</p>
 <p>Part No. USN</p>	<p>JDL Universal Resin Shutoff & Gas Injection Nozzle</p> <p>The <i>latest</i> advance in gas assist shut-off nozzle design. The patented Universal Self Actuating Nozzle (USN) has an overall length of only 5 1/2 inches and can be used on any molding machine 20 tons and larger. The USN's standard threads are 1 3/4 "- 8. Special threads <i>are</i> available.</p>
 <p>Part No. AGSA-1</p>	<p>AEGIS Resin Shutoff & Gas Injection Nozzle Adapter</p> <p>The AGSA-1 enables using any standard resin injection nozzle for gas injection by assembling the AGSA-1 between the nozzle and your standard nozzle tip. Standard threads each end are 7/8-14 Includes gas port, requires gas line check valve. See ACV-02</p>
 <p>Part No. GIN-8 (8") Part No. GIN-10 (10") Part No. GIN-12 (12")</p>	<p>JDL Gas Assist Injection Nozzles provides Class-One performance at an affordable price when injecting gas through the nozzle. In stock in 8", 10" and 12" lengths. Gas assist ready.</p> <p>Part No. ACV-02 or DET 2-C required for affixing high-pressure SS gas line.</p>
 <p>Part No. DET 2-C</p>	<p>NitroJection Self Actuating Gas Assist Nozzle Check Valve</p> <p>Gas assist nozzle check valve fits into a gas assist nozzle or any NitroJection gas assist shutoff nozzle, between the gas line and the nozzle or shutoff.</p> <p>The unit prevents resin from returning to the gas line. This component is necessary when using the any gas through-the-nozzle</p>

application.

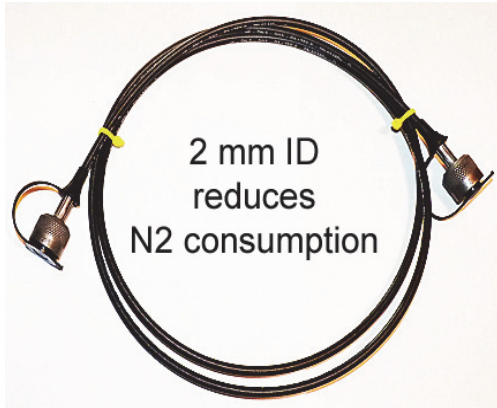

NitroFlex High Pressure Gas Lines & NitroFlex Connectors

Working pressure of 9,200 PSI (630 bar)

Easy, fast connection of gas-assist controllers to injection mold. Special hose threads fit *only* NitroFlex Connectors for safety.

Eliminate the aggravation of 1/8" stainless steel for connecting to the mold!

Connectors, hose connector unions, shown below. NitroFlex hoses, and the connectors and unions, have special threads that make them compatible ONLY with each other as a high-pressure line safety feature.

Description

Part number

Delivery

NitroFlex-hose - 6 ft length

SMP2-72

Usually in Stock

NitroFlex-hose - 10 ft length

SMP2-120

Usually in Stock

NitroFlex-hose - 15 ft length

SMP2-180

Usually in Stock

NitroFlex-hose - 20 ft length

SMP2-240

Usually in Stock

Custom-order lengths available to suit your application – 7 day delivery

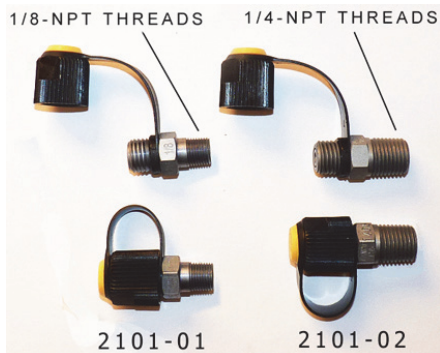

Description

Part number

NitroFlex connector 1/8 NPT
Rated for up to 6,000 PSI for HP gas line to mold only

2101-01

NitroFlex connector 1/4 NPT
Rated for up to 10,000 PSI for gas controller outlet ,or mold

2101-02



NitroFlex Union Connector,
For joining (2) hoses for extended length
(open union – no check valve)

2101-U

NitroJection Gas Assist Molding Systems



New and Recertified Gas Assist Molding Systems

(Recertified half or less than the cost of new equipment)

Repair and Rebuilding of ALL Makes of Gas Assist Systems. by

8430 Mayfield Road, Ste. 120 Chesterland, OH 44026

nitrojection.com

440-729-2711

NitroJection offers gas assist controller parts, repairs and complete system rebuilds, a *unique* service in our industry, servicing *all* gas assist controllers and booster from any manufacturer.



NitroJection is the first, and *only* gas assist technology company to offer system inspection and repairs to bring your system up to date and performing as when new. Following receipt of your equipment, we perform a *thorough* analysis of the system's condition and submit a report of the findings including a detailed proposal to bring it up to original performance.

Call us at 757-271-9927 for more information, or NitroJection Corp. directly at 440-729-2711.

Gas Assisted Injection & Compression Molding
Systems, Product-Process Development, Component Hardware
757-271-9927

AEGIS A3SC and A4SC Series Gas Injectors - Basic Dimensions:

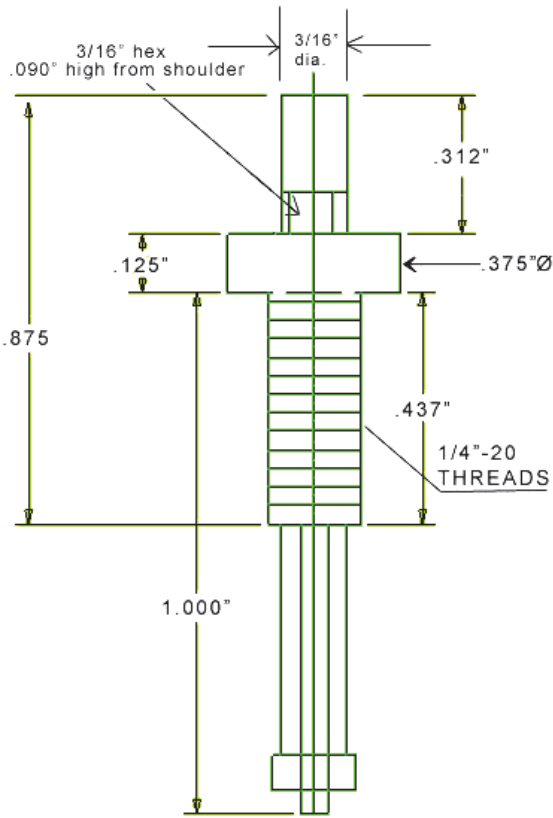

A3SC312TS (O1 tool steel)

A3SC312SS (316 stainless steel)

A5SC312TS-D (O1 tool steel with titanium nitride)

A4SC312TS (O1 tool steel)

A4SC312SS (316 stainless steel)

A6SC312TS-D (O1 tool steel with titanium nitride coating)

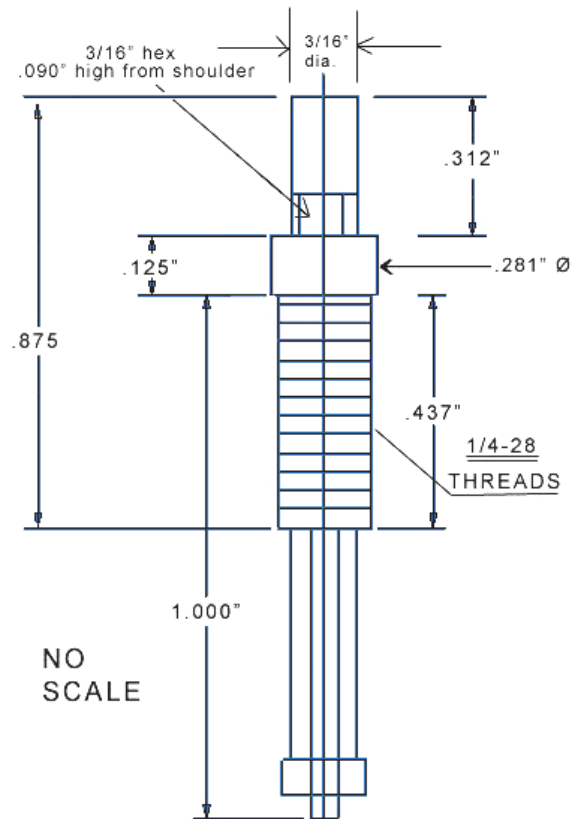

AEGIS A3SC and A4SC Series Basic Assembly

A3SC and A5SC Series – assembly is with 1/4-20 threads, .4375" long. Bore the tool per the graphic below. An O-ring is supplied with each injector that fits above the threads and below the injector body shoulder. The A3SC (and A4/5/6SC Series) is assembled into the mold with a 3/16" deep socket. We recommend a 3/16" nut driver or deep hex socket with the opening "faced off" to accommodate a flush-surface fit on the 3/16" hex and injector base. No pliers or vice grips!

Assembly of the injector is *not* to a torque specification; position the upper surface of the injector shoulder flush with the surface of the tool steel, which will slightly compress the O-ring to further prevent gas from leaking past the threads

Note: The A3SC injector shoulder is .125" thick; the O-ring is approximately .060" thick. The bore that receives the injector shoulder is 3/8" diameter reamed, .180" deep. These dimensions are recommended for proper fit of the injector with *slight* compression of the O-ring. (5 spare O-rings are furnished with each injector)

AEGIS A3SC and A5SC Series Installation in Mold

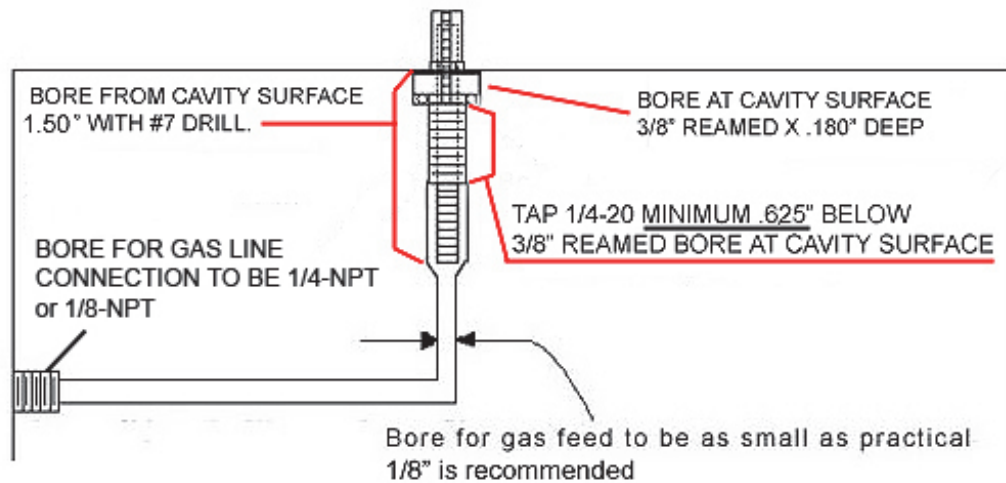

The **A4SC** and **A6SC** Series – 1/4-28 threads x .4375" long. Bore the tool per the image below. No O-ring is used for this series. The upper .125" of the tool bore is bored to .281" to locate and seat the shoulder in the bore. For assurance of seal of the threads in the tool steel, use Teflon® tape on the threads of *all* gas injectors. Do not allow any tape to enter the opening on the inlet side.

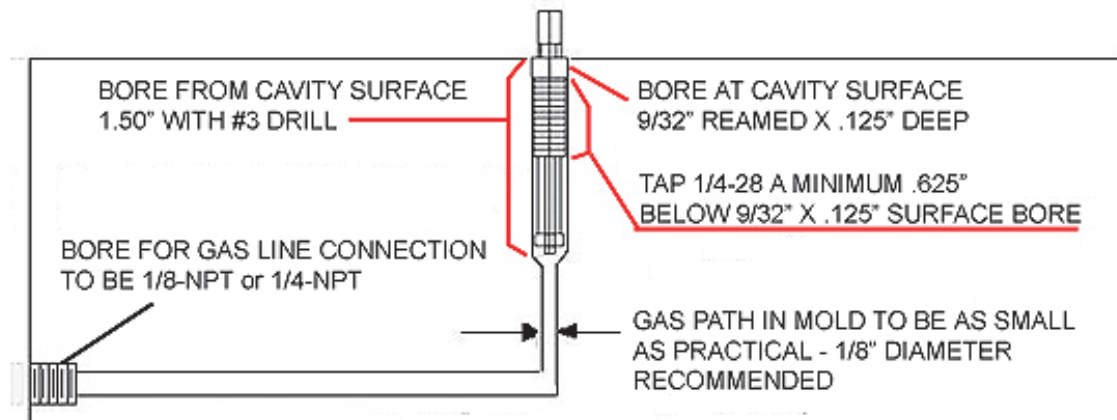

Gas Injector Operation: All AEGIS gas injectors have an open vent at all times to allow precise cavity/process pressure profiling during the gas injection process. Pressure profiling is necessary by varying degrees to prevent gas penetration into areas of the molded part where it is not acceptable, and, to eliminate the need for secondary methods to release the gas pressure. It also assists in eliminating hesitation lines on the molded part surface by “ramping up” at the *start* of the gas injection sequence with little or no delay time from the gas injection start signal. (Note: The “start signal” for gas injection should always be at the “end of shot,” not at the start of resin injection!) AEGIS injectors require no hydraulic, pneumatic, or electronic actuation; they remain static in the mold - the A3SC, A4SC, A5SC and A6SC Series opens to a *larger* vent upon gas injection, resulting in unequalled gas-flow capabilities, and to achieve their self-cleaning function.

Note: It is *always* best to maintain gas pressure throughout the cooling cycle, as this keeps the exterior of the molded part against the tool cavity surface for maximum cooling efficiency. Venting (gradual pressure reduction) should begins 8 to 10 seconds before the end of the cycle following the final gas injection pressure, and be reduced to “0” only a few seconds before the mold is set to open. Gas assist controls with pressure ramping capabilities are strongly recommended for optimum results. Not all controls have this capability.

A note about tool steel (O1) vs. stainless steel gas injectors:

We recommend O1 tool steel gas injectors for most applications. We recommend 316 stainless steel gas injectors *only* when processing corrosive resins such as PVC or flame retardant resins. O1 tool steel injectors perform better in all other resins due to their superior resistance to abrasion, particularly in reinforced resins. Our A5SC and A6 SC Durajectors are the most wear resistant gas injectors in the industry.

E-mail AEGIS at gas101@gaspins.com or give us a call at 757-271-9927 for more information, or if you have any questions whatsoever about your specific application.

A E G I S

AEGIS CONSULTANTS, INC.

P O Box 307 Pierre Part LA 70339 USA

757-271-9927 e-mail: gas101@gaspins.com

www.gaspins.com

www.nitrojection.com

Gas Assisted Injection & Compression Molding
Systems, Product-Process Development, Component Hardware
757-271-9927